

Operators Position

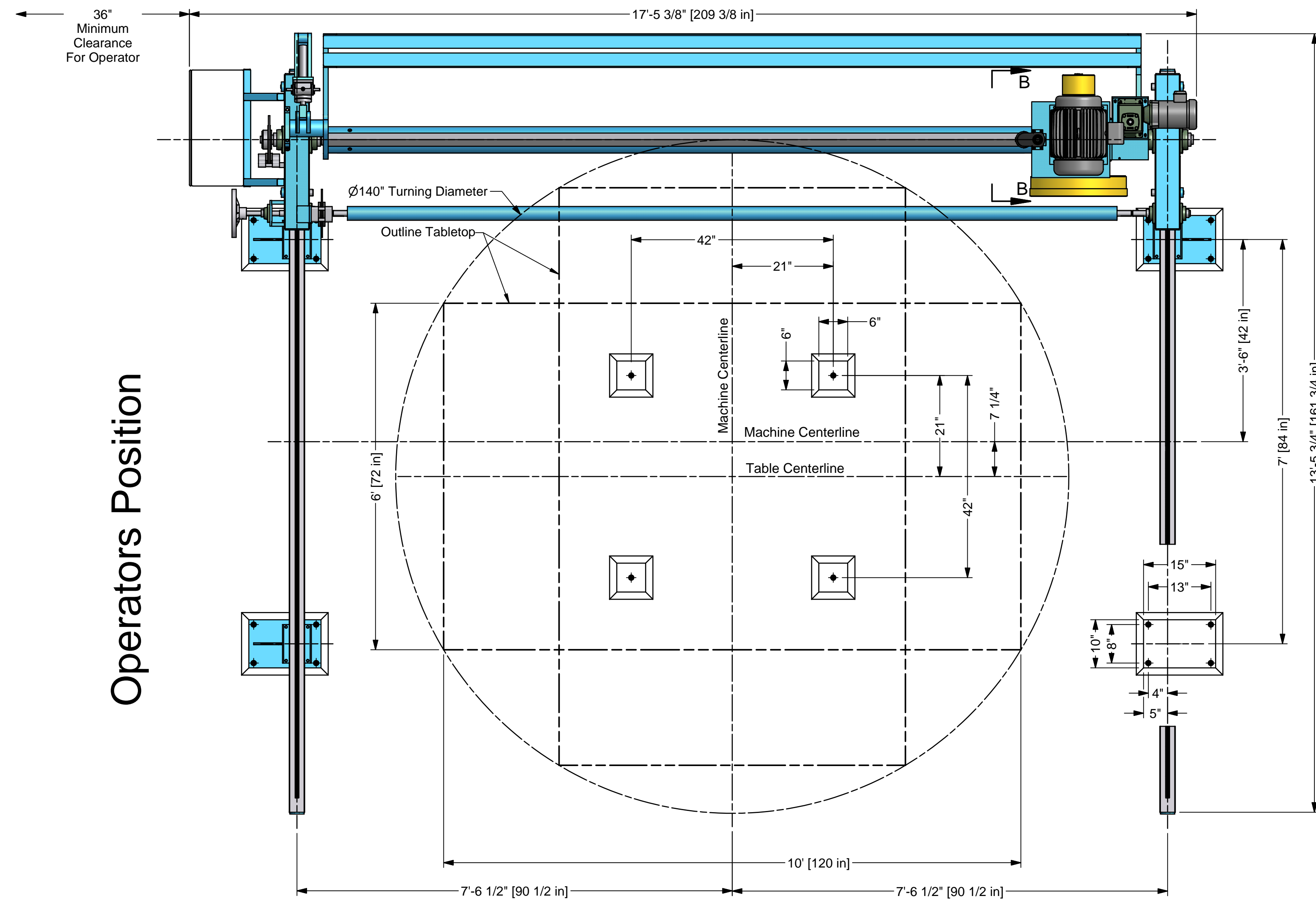

Operators Position

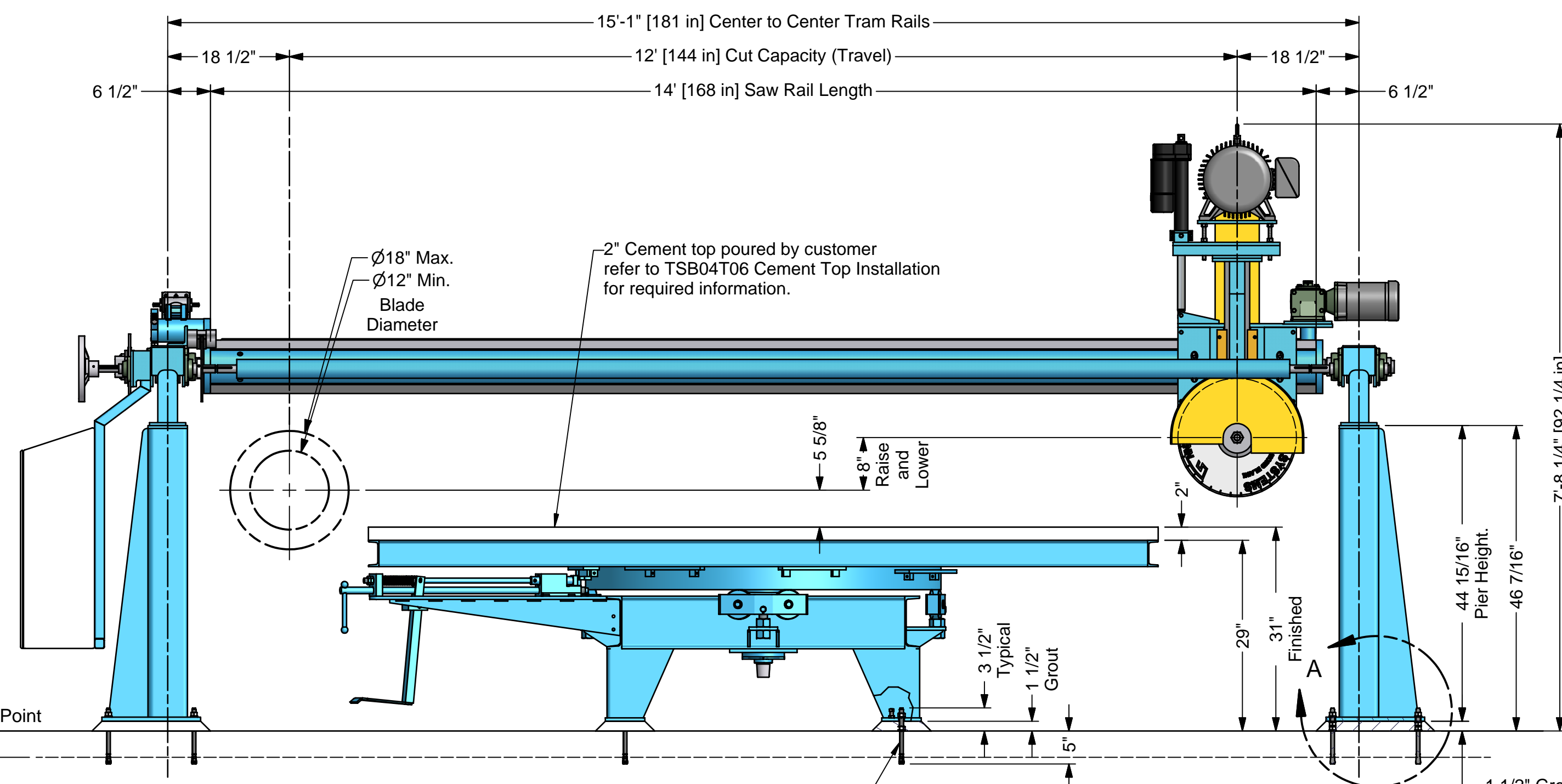

Operators Position

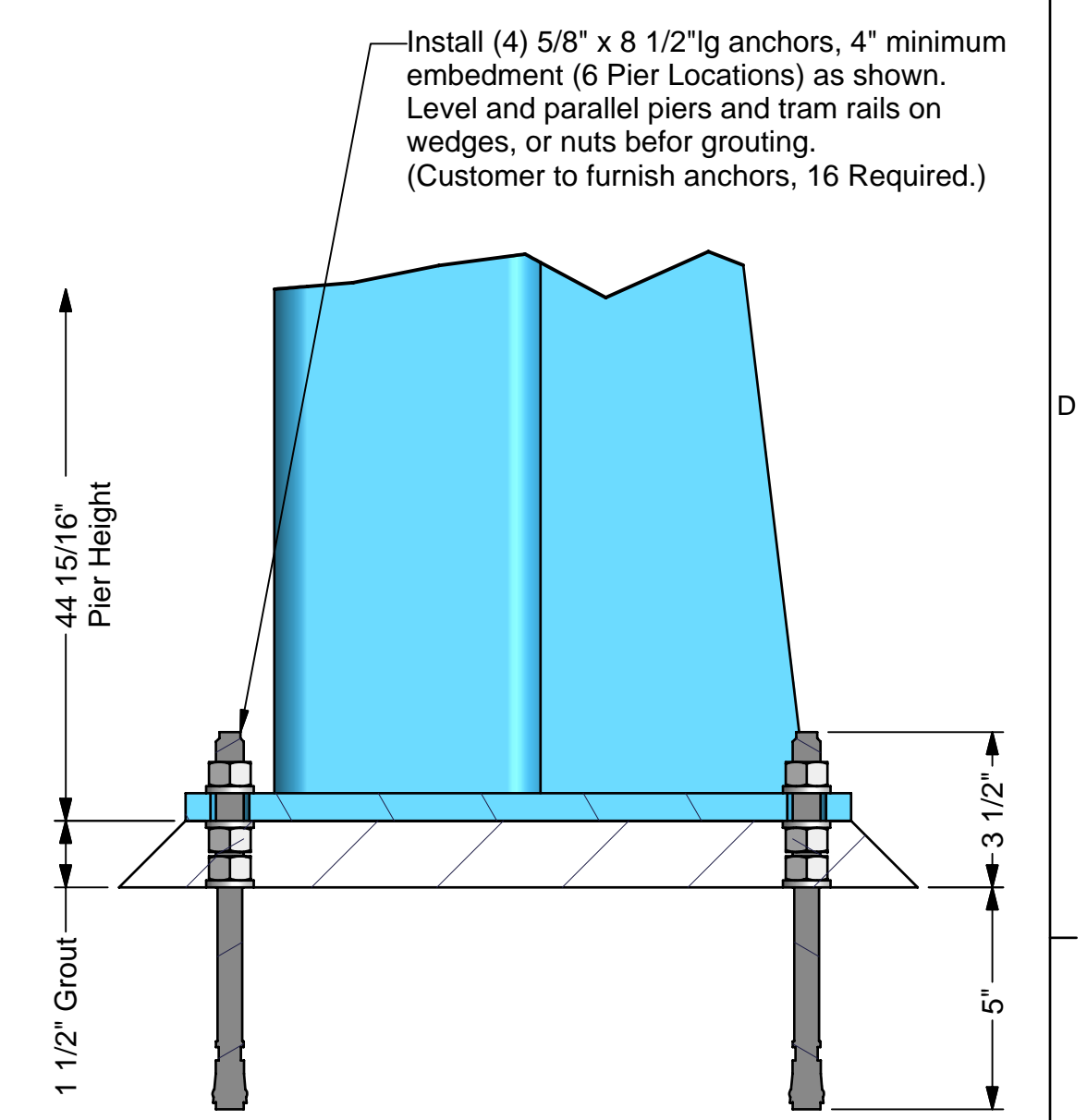

DETAIL A SCALE 1/4

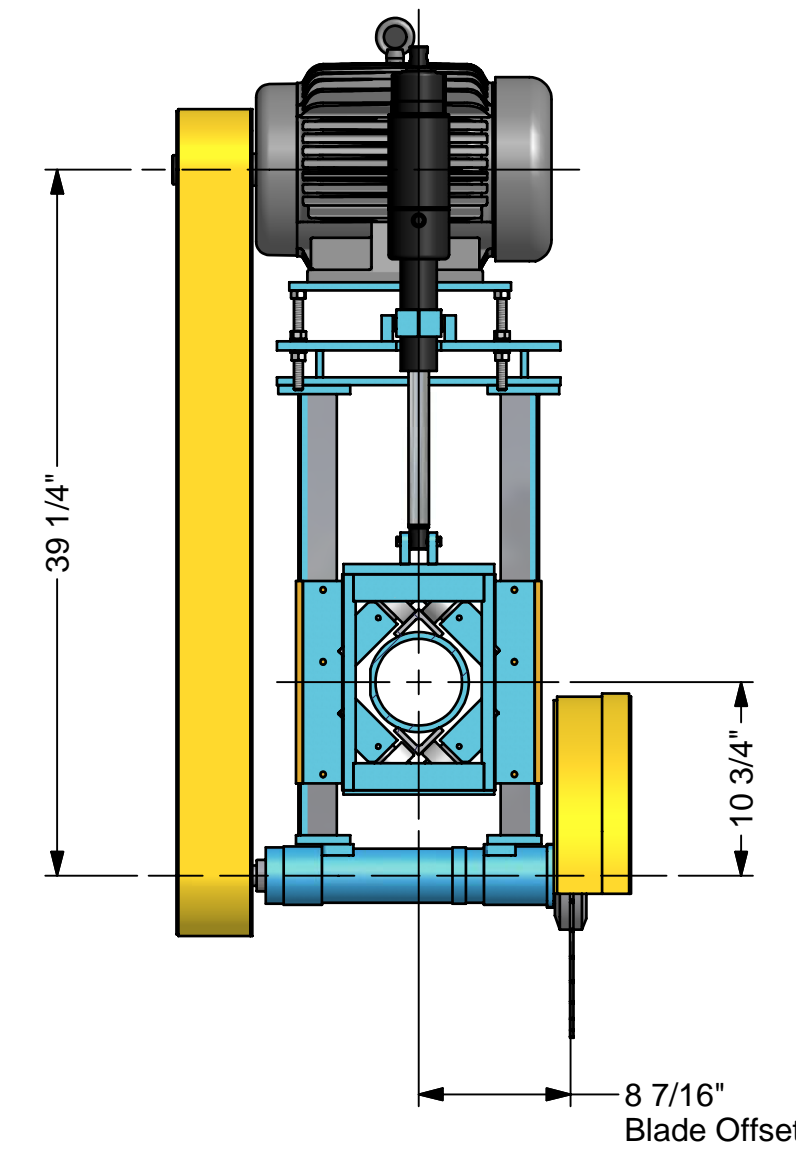

SECTION B-B SCALE 0.09 : 1

ITEM	QTY	PART NUMBER	DESCRIPTION
5	1	E-4012-19B	Assembly - Standard Turntable
4	1	E-5025-9	Assembly - 551C Gantry Saw
3	2	B-4307-3	Weldment - Tram Rail Assembly
2	4	B-4002-14A	Weldment - Steel Pier - 44 15/16" Height

RELEASED	DATE	DIMENSIONS ARE IN INCHES AND DEGREES UNLESS OTHERWISE NOTED. DIMENSIONING AND TOLERANCES IN ACCORDANCE WITH ANSI Y14.5-1994
APPROVED	DATE	
PROJ. MGR.	DATE	FRACTIONS DECIMALS ANGLES ± 1/16" .X ± .050 ± .06" .XX ± .010 .XXX ± .005
MATERIAL:		BREAK AND DEBURR ALL SHARP EDGES
WEIGHT:		THIRD ANGLE PROJECTION
NEXT ASSEMBLY		

**SAWING SYSTEMS INC.**  
 P.O. Box 3754 • Knoxville, TN 37927-3754 • (865) 525-0600  
 (800) 489-0601 • Telefax (865) 525-2320

TITLE: Model 551C  
**Foundation and General Arrangement**

DRAWN: DLL	SCALE: 1:16	DWG/PART NO: E-5025-12-1210	SIZE: E	SHEET 1 OF 1
DATE: 5/20/2005	WEIGHT:			REV

This drawing is the property of SAWING SYSTEMS Incorporated, including all patented and patentable features, confidential information and use hereof is conditioned upon the user's agreement not to reproduce the drawing, in whole or part, nor the material described thereon, nor the use of the drawing for any purpose other than specifically permitted in writing by SAWING SYSTEMS Incorporated.